



ISSN Print: 2394-7500
ISSN Online: 2394-5869
Impact Factor: 5.2
IJAR 2015; 1(8): 01-04
www.allresearchjournal.com
Received: 20-06-2015
Accepted: 30-06-2015

Udaykumar S. Kulkarni
PG Student Department of
Electronics and
Telecommunication, G. S.
Moze Collage of Engineering,
Savitribai Phule Pune
University, Pune, India.

Venkat N. Ghodke
Asst. Professor Department of
E & TC, AISSMS'S Institute of
Information Technology,
Savitribai Phule Pune
University, Pune, India.

Correspondence:
Udaykumar S. Kulkarni
PG Student Department of
Electronics and
Telecommunication, G. S.
Moze Collage of Engineering,
Savitribai Phule Pune
University, Pune, India.

An adaptive industrial boiler automation application using FPGA & GSM

Udaykumar S. Kulkarni, Venkat N. Ghodke

Abstract

The revolution of automation on factory floors is a key driver for the more demand for higher productivity, lower total cost of ownership, and high safety. As a result, industrial applications drive a more demand of higher data bandwidth and higher system-level performance. This article describes the trends of industrial applications and FPGA enable solutions to meet design goals.

The broad range of FPGA devices - ranging from low cost and low power to higher content and higher performance, facilitates designs in varying ranges of complexity, from simple I/O expansion to complex computation and system integration. FPGAs meet critical timing and performance requirements with parallel processing and real-time industrial application performance, permitting greater system integration and lower development cost.

We propose the design and implementation of boiler automation, the water level in the main tank is controlled by a water level sensor, each boiler has two pipes, one is inlet other one is outlet and the pipes valves are controlled by temperature sensors located in each boiler. From the GSM mobile phone, the user will be able to get information about the current temperature in any boiler by simply sending a boiler identification number. When the temperature inside any boiler reach a maximum presented value, the system will send a SMS to the user informing that the maximum temperature has been reached. The design can be described using VHDL (VHSIC Hardware Description Language) and implemented in hardware using FPGA (Field Programmable Gate Array), GSM modem and sensors.

Keywords: Boiler, FPGA, GSM, Sensor and Temperature.

1. Introduction

Power plant section is one of most important department in the industry. The steam is produced in boiler when water temperature in boiler is increased to steam level temperature. The boiling section produces the high temperature water to the steam level. This steam level temperature water is used for power generation by applying steam water to the turbine section^[8].

The control system for a boiler unit usually needs to meet the requirement of the amount of water in the steam drum must be maintained at a desired level by maintaining the water level in main tank to prevent overheating of the drum or flooding of steam lines. This is critical for the safe and economic operation of a power plant. The drum level must be controlled to the limits specified by the boiler manufacturer. If the drum level does not stay within these limits, there may be water carryover. If the level exceeds the limits, boiler water carryover into the super-heater or the turbine may cause damage resulting in extensive maintenance costs or outages of either the turbine or the boiler. If the level is low, overheating of the water wall tubes may cause tube ruptures and serious accidents, resulting in expensive repairs, downtime, and injury or death to personnel. A rupture or crack most commonly occurs where the tubes connect to the drum^[8].

After the power is generated, steam water is supplied to various plants for reuses. Here, we are automating the boiler system by monitoring boiler flame sensing, temperature and controlling the water tank levels. If the process values of temperature, water level and flame sensing exceed the set values, then SMS will be sent to Operator and other concern persons using GSM.

The hardware of the controller chip has been designed using VHDL and has been tested using Xilinx FPGA. First a synthesizable VHDL code has been written and simulated using Xilinx ISE 6.2i tools, and then implemented on a Xilinx Spartan 3 FPGA. The design has

been successfully simulated and tested for both sensing and controlling purposes at different frequencies. This section of the article gave an introduction to the presented work, the next section gives some details about the Hardware, system architecture and operation, in section III we are giving some details about the VHDL Top Level Model and RTL schematic of the design and simulation results given in section IV, at the end conclusions about the work done and future scope will be given in section V.

2. System Architecture and Operation

The main objective of this project is to measure the boilers temperature, tank level and flame sensing measured in analog form. A circuit, having IC-LM 35 temperature sensors, measures the temperature of the boilers and Level sensor measures the level of the water tank. Similarly the flame sensor measure the boiler is in flaming. The obtained temperature, level and flame measuring data are transferred through the FPGA controller. The controller read the available data and processed. Then the controller has been connected to the interface circuit and the GSM Modem through the serial port of the GSM Modem. The controller consists mainly from three components, the Control Unit (CU), ROM, and UART (Universal Asynchronous Receiver Transmitter). The VHDL code also includes a communications through the AT commands of the GSM Modem [5-8].

A. Hardware Description

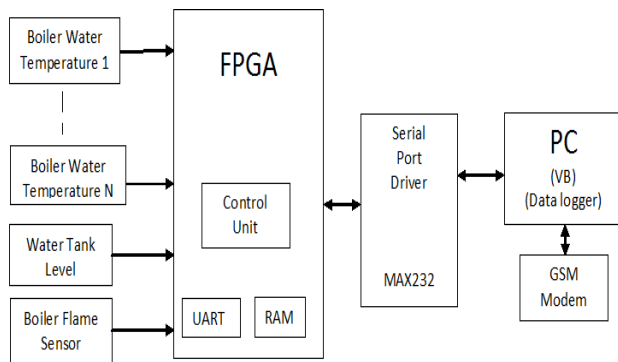

Fig 1: Block Diagram of Boiler Automation

B. Temperature Measurement Descriptions

- 1) *Principle of Temperature:* Temperature is the degree of hotness or coolness of a body. When the temperature changes, the internal Resistance also changes to the corresponding material [2].
- 2) *Sensing Device:* A sensor is a transducer. The output of the transducer is in the form of voltage current, resistance, or capacitance. The block diagram summarizes the above discussion [8].

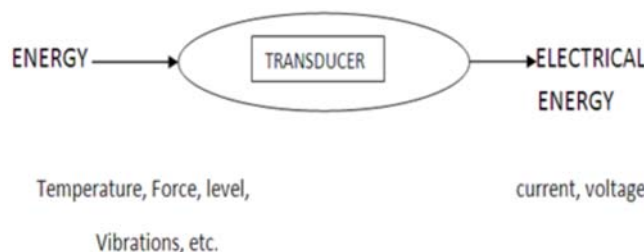
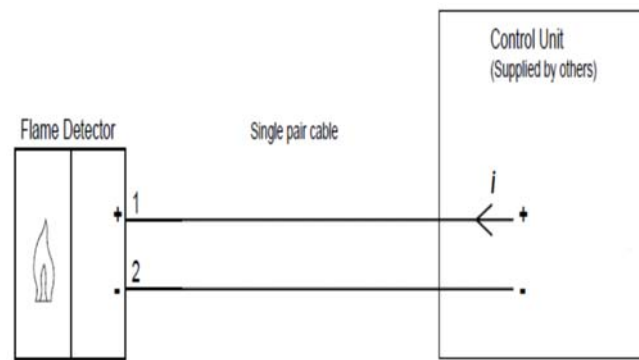

Fig 2: Temperature Measurement Diagram

In this development, high temperature is calculated; LM35 is used to measure the temperature in the range of -55°C to +150°C. The LM35 series are precision integrate-circuit temperature sensors whose output voltage is linearly proportional to the Celsius high temperature. The LM35 hence has an improvement more than linear temperature sensors calibrated in ° Kelvin, as the user is not required to subtract a large constant voltage from its output to obtain convenient Centigrade scaling. If we want to measure temperature greater than 1000°C we have to use Thermocouples [1].

C. Flame Detector

The flame detector is designed for use where open flaming fires may be expected. It responds to the light emitted from flames for the duration of fire. The detector discriminates connecting flames and other light sources by responding only to particular optical wavelengths and flame flicker frequencies. This enables the detector to avoided false alarms due to such factors as flicking sunlight [1-8].



3. VHDL Top Level Model and RTL

Figure 4 shows the VHDL Top Level Symbol that clarify the interface of the main controller, where Clk, Rst, GSM_Rx, and Sensors<0:24> are inputs, and GSM_Tx, and Devices<0:24> are outputs. GSM_Rx has to be connected to Tx of GSM, and GSM_Tx has to be connected to Rx of GSM [5].



Fig 4: VHDL Top level model

Both GSM_Tx and GSM_Rx are connected to GSM through RS 232 converter. Which converts RS232 voltage level to TTL voltage level in case of receiving data from GSM and converts the TTL voltage level to RS 232 level in case of sending data to GSM Modem [6].

Fig. 5 shows the register transfer level schematic generated from the VHDL code. The VHDL program has many components and functions, the most important components are UART Receiver (U0), Memory unit (U1), Sensing unit (U2), Control Unit (U3) and UART Transmitter (U4). The main function of UART receiver is to convert the serial data received from the GSM Modem into parallel data to be processed. The memory unit holds the telephone numbers of the Operator and other concern persons. The sensing unit connected directly to the input sensors and the UART

transmitter through the multiplexer [5]. The control Unit is the most important component in this system it generates the AT commands, process the received SMS messages and act according to the contents of the messages, it also send SMS messages to the user in case of emergency. The main function of UART Transmitter is converting the processed data from parallel to serial and then sending serial data to GSM Modem, the transmitted data could be an AT command, SMS messages to the users

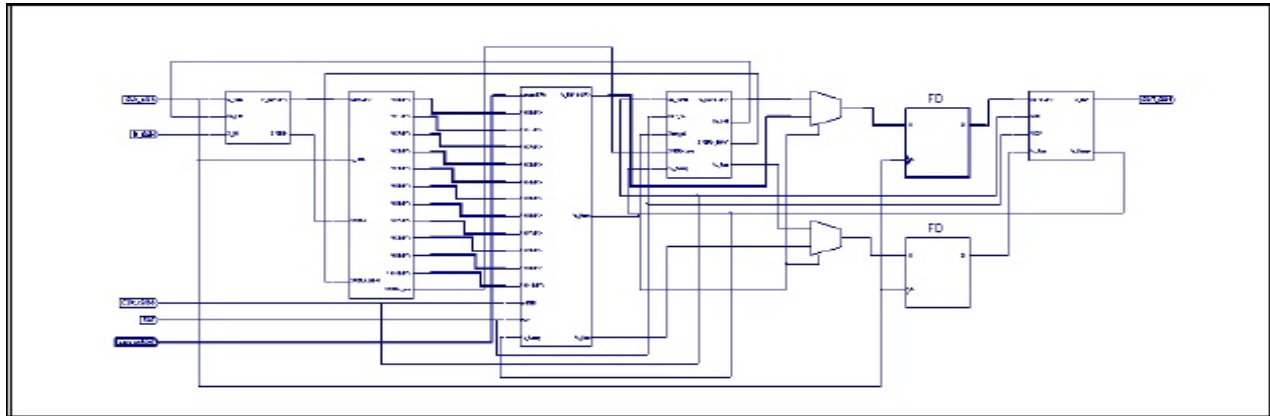

Fig 5: Register Transfer level Schematic

4. Simulation Results

The system has been experimentally tested for both sensing and controlling purposes first with serial port of the PC, then in a real time using GSM. Figures (6-8) show the simulation results for the control Unit, the UART Transmitter, and UART Receiver. Figure (6) shows the simulation for the Control Unit which sends parallel data to UART Transmitter; the parallel data represents the ASCII code for the characters; the character could be a message or an AT commands. The example given in figure (6) is for sending the AT commands for reading message in location 1 "AT+CMGD=1", '\$' and '#' are used for the start and end of the transmitted data. In the simulation we show the transmitted data in the form of characters but in hardware implementation it is stream of bits that represent the ASCII codes of the characters. In Figure (7), the UART Transmitter is shown in which there are two state, the first one is for preparing data in a frame of 10-bits including the start and stop bits, and the next state is for sending the frame to the serial output S_out, where k is a counter for the number of bits to be send in the second state, and Tx_req and Tx_ready for handshaking. In Figure (8), the UART Receiver is shown, where reg_GSM is a shift register, the input serial data from S_in is shifted in reg_GSM after receiving the start bit, and when rx_en is high, after shifting the 8-bits of the received character and the stop bit, the ASCII character in reg_GSM has to be assigned to P_out.

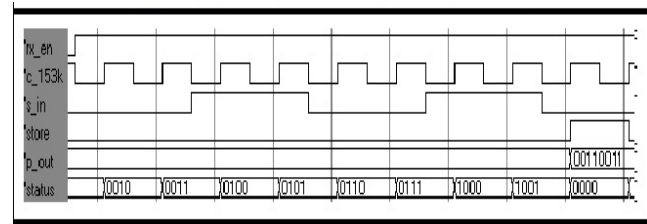

Fig 7: Simulation results for UART Transmitter

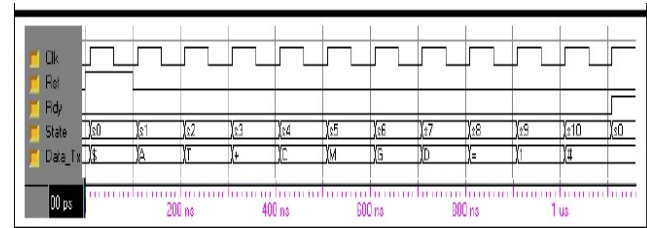

Fig 8: Simulation Results for UART Receiver

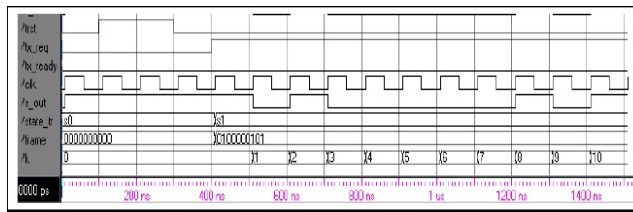

Fig 6: Simulation results for the Control Unit when sending AT commands

5. Conclusion

In this paper we have introduced a controller design for boiler automation with a remote sensing system by using FPGA and Global System for Mobil (GSM). The system has been designed and hardware is implemented on Spartan 3 FPGA by using VHDL language. The design was simulated and tested in a hardware level and verified the correctness and working operation of the whole system. The FPGA was selected as, compared to microcontrollers, it provides a larger number of input/output ports and the parallel implementation of hardware results in faster algorithm execution. The user interface on the mobile phone communicates with the FPGA using the GSM interface. This leads to a low cost system that can be easily scaled up. As it uses GSM interface the system can be used in remote areas also.

Future Scope

Industrial process control is concerned with maintaining the output of a specific process within a desired range. FPGA logic provides a powerful compute solution to monitor the data while easily performing filtering, threshold comparison, and control operations. The PLC designer can integrate flexible high-performance DSP functions, microcontrollers, logic functions, and data processing capable of handling millions of data samples per second—far in excess of some of the highest performance Microprocessors.

Industrial Safety systems have always been a critical component of the manufacturing environment, responsible for monitoring the general health and operation of the manufacturing equipment and shutting down a process when something operates outside its specifications. Smart sensors and actuators with integrated safety features, such as diagnostics and testing, typically integrate an analog sensor or multiple sensors with digital control logic to ensure that distributed control systems are continuously monitored for maximal safety.

Acknowledgement

It gives me immense pleasure to thank the Head of Department, Prof. Neelam Sonawane and our PG coordinator Prof. Suchitra Jagtap for giving me an opportunity to present this paper. I would extend my sincere gratitude to my guide Prof. Venkat Ghodke, for his regular inputs and for constantly guiding me. I am obliged to all my friends for the valuable information provided by them as and when necessary.

References

1. Srinivas Gopu, G Shyam Kishore. “Monitoring Of Home & Activation of Automated System Via GSM Through FPGA”, International Journal of New Trends in Electronics and Communication (IJNTEC—ISSN: 2347

Jan, 2014, 2(1).
 2. Yadav Vajrangshakti Ramdayal1, Srinivasa Rao K., An Adaptive Industrial Automation Application Design using ASIC; International Journal of Reviews on Recent Electronics and Computer Science. IJRRECS/October /1093-1099 ISSN 2321-5461, 2013, (1)6.
 3. Christin John Thomas. “Intelligent Sensor Based Building Automation and Energy Management. International Journal of Advanced Research in Computer Science and Software Engineering Volume 3, Issue 8, August ISSN: 2277 128X, 2013.
 4. “Implementation of a Home Automation System through a central FPGA Controller – IEEE Journal – Electro technical conference (MELCON) 25-28, March, 2012.
 5. Wael M El-Medany, Mahmoud R El-Sabry. “GSM-Based Remote Sensing and Control System Using FPGA”, Proceedings of the International Conference on Computer and Communication Engineering 2009 May 13-15, Kuala Lumpur, Malaysia, 978-1-4244-1692-9/08/\$25.00 © 2009 IEEE, 2009.
 6. Xuemei Li. VLSI & System Laboratory, Beijing University of Technology, China ; Yuan, Qiuchen ; Wuchen Wu ; Xiaohong Peng, “Implementation of GSM SMS remote control system based on FPGA”, Information Science and Engineering (ICISE), 2nd International Conference on IEEE - 10.1109/ICISE.2010.5691440, 2010.
 7. Piyare R, M. Tazil, “BLUETOOTH BASED HOME AUTOMATION SYSTEM USING CELL HONE”, IEEE International Symposium on Consumer Electronics, 2011, 15.
 8. Karuppiah T, Dr. Periasamy, Dr. Muruganand S. “Embedded System Based Industrial Power Plant Boiler Automation Using GSM Technology”, International Journal Advanced Research in Computer and Communication Engineering, August 2013, 2(8).

Author Profile



Udaykumar S. Kulkarni received his B.E degree in Electronics and Telecommunication Engineering from REC Bhalki, Gulbarga University, Gulbarga, Karnataka State, India, And he is pursuing M.E degree in Electronics Engineering specialization with Digital System from Savitribai Phule Pune University, Pune, Maharashtra, India. His Area of interests is Embedded Systems & Automation.



Venkat N Ghodke received the B.E. degree in Electronics Engineering from Dr. B. A. M. University, Aurangabad, Maharashtra, India, in 1997, and the M.E degree in Electronics Engineering specialization with Digital System from Pune University, Maharashtra, India, in 2010. Currently He is an Assistant Professor in AISSMS’S Institute of information technology of Savitribai Phule University of Pune, India. His research interests include digital image processing and embedded system area.